

DATASHEET

T BEND FOR MEDIUM DUTY CABLE TRAY W450 H25

FEATURES:

- Flat 90 degree bend have two width dimensions and are produced equally.
- There are holes in the flat 90 degree bend base.
The cable tray is fixed with M8x15 bolts and nuts to coincide with these holes.
- Width dimensions can be produced differently.
- **Example:** In special productions, the dimensions must be clearly specified.
It can be produced as X:450mm, Y:300mm, the size expression should be 450/300 when defining the product.
These products cannot be changed and returned as they will remain fixed after production.
In special productions, the code is specified according to the larger size.
- It can be produced in required thickness from 0.80mm to 2.00mm.

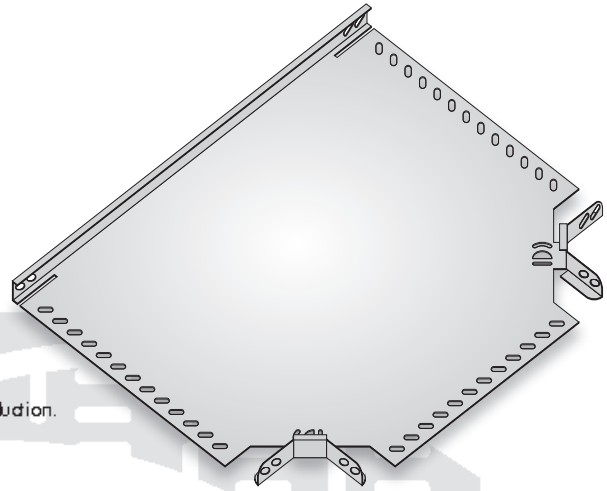

DESCRIPTION:

Product Code

DM-ATD45025

Height (h)

Width (w)

Medium duty cable tray T Bend (ATD)

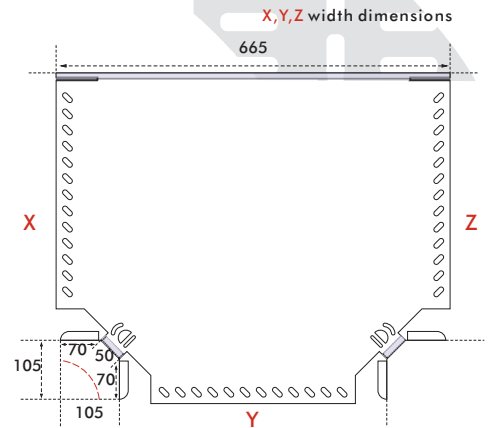

DIMENSIONS:

Width (w) : 450

Thickness (t) : 1,2

Height (h) : 25



How to install?

When the cable tray coincides with the holes on top of the flat T bend it is fixed with m8x15 bolts and nuts.

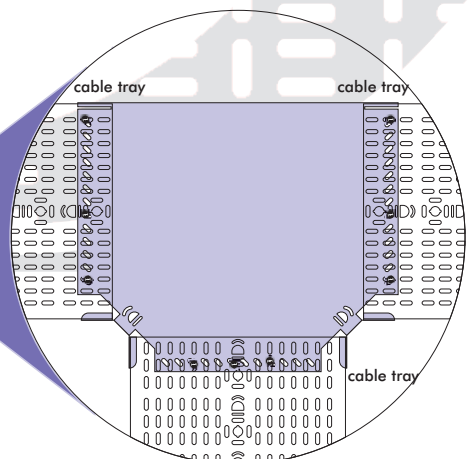

COATING

PG Pre-Galvanised Steel

HDG Hot - Dip Galvanised Steel

EPC Electrostatic Powder Coating

SS Stainless Steel

Prices vary according to the type of coating in the offer. You must specify the type of coating in your offer list.